

## **CALCULATION AND REFINEMENT OF THERMODYNAMIC PARAMETERS FROM THERMOMETRIC TITRATIONS. I. IONIZATION ENTHALPIES OF AMINES IN AQUEOUS AND HYDRO-ALCOHOLIC MEDIA**

J.M. ESTELA, M. FAR and V. CERDÁ

*Department of Chemistry, University of Illes Balears, E-07071 Palma de Mallorca (Spain)*

(Received 16 February 1989)

### **ABSTRACT**

A comparative study of a number of methods for calculation and refinement of thermodynamic parameters from thermometric titrations has been performed.

These methods were applied in order to determine the ionization enthalpies of different amines in aqueous and hydro-alcoholic media. The influence of the medium on the titration errors, and its precision, was also taken into account.

### **INTRODUCTION**

Thermometry has been widely used in the titration of acids in water, as well as in non-aqueous media [1–10], not only to evaluate the applicability, accuracy and precision of the technique, but also because it is a rapid way to accomplish precise values of  $\Delta H^\ominus$ ,  $\Delta G^\ominus$  ( $pK_a$ ) and  $\Delta S^\ominus$  for the ionization processes.

Thermometric titrations of *N*-bases have also been carried out in both aqueous and non-aqueous media [11–13].

The advantages of non-aqueous and mixed solvents in the titration of acids and bases are well known. If the enthalpy of the reaction is not unfavourably affected by changing the solvent, its use would be very encouraging in thermometric titrimetry, as lower heat capacities give rise to titration graphs with higher slopes.

This unfavourable effect was discussed in a former paper, where the influence of the medium on the thermometric titrations of carboxylic acids was determined [14].

The aim of this research was to perform a comparative study of the results obtained when different computing methods were applied to determine the neutralization enthalpies of a number of amines in water and methanol–water media. The influence of the media on both the quality of the analytical

results (exactitude and precision) and on the values of the thermodynamic parameters was also assessed.

## EXPERIMENTAL

### *Apparatus*

An automatic thermometric system, described elsewhere [15], was used. This system consists of a CRISON automatic burette connected to an IBM-PC computer via a RS232C serial interface, an adiabatic cell, and a 100 K $\Omega$  thermistor connected to a Wheatstone bridge. The voltage output of this bridge was amplified ( $\times 10$ ) and then measured by a Crison digital potentiometer, which acted as an A/D converter and was connected via the RS232C to the computer. The computer controlled the overall system and stored the acquired data.

A special program, VALTER \*, for data acquisition, representation and computing, was developed. This program, described elsewhere [15], stores and controls the experimental conditions (like that titrant volume to be added, addition speed, base line stability, etc), performs the titration tasks, acquires the data (which are stored in the appropriate file), represents the titration curves, and fits and extrapolates the linear intervals in order to automatically detect the equivalent points.

Data files accomplished by VALTER were appropriately modified for direct use in calculations and refinement.

### *Heat capacity of the cell*

In all titrations 50.0 ml of the sample were used and the heat capacity of the system was determined under the same experimental conditions, by introducing a known quantity of heat by means of an electrical calibration system. Average values of 52.4 and 41.65 cal °C<sup>-1</sup> were found for water and methanol–water (50% v/v), respectively.

### *Reagents*

Hydrochloric acid solution in water and in methanol–water (50% v/v) was standardized with sodium hydroxide, which was in turn standardized using potassium hydrogen phthalate. Organic amines of the best quality available were used. Analytical grade reagent chemicals were employed.

---

\* VALTER and the other programs mentioned in this paper can be requested from SCIWARE, Department of Chemistry, Universitat del les Illes Balears, E-07071 Palma de Mallorca, Spain.

### Procedure

All titrations with hydrochloric acid were carried out by placing the amine in the thermometric cell in the appropriate medium. The reagent was added when the sample reached thermal equilibrium, which was defined in the experimental data conditions input as the maximum base line slope value allowed ( $0.001^{\circ}\text{C min}^{-1}$ ).

Once the thermal stability criterion was accomplished, the data acquisition began, first saving 10 consecutive points of the base line that fitted a straight line with a minimum correlation coefficient ( $r = 0.999\dots$ ), and then adding the titrant at a constant rate. As a great number of experimental points of the postequivalence were required for linear extrapolations and for the MINITERM program, an excess of titrant was added in all cases.

### COMPUTING AND REFINEMENT METHODS

The aim of the computing methods is to apply approximate values of the neutralization enthalpies, which are then used as starting values for the refinement program.

#### *Calculation of the parameters for monoamines*

##### *Overall heat capacity method*

This derives from the classic calorimetric method and consists of measuring the total temperature variation produced in the titration of  $n$  moles of a substance, assuming a complete reaction, and applying the equation  $\Delta H^{\ominus} = -Q/n = -c \Delta T/n$ , where  $Q$  is the evolved heat and  $c$  is the heat capacity of the cell and its contents.

##### *Point-by-point heat capacity method*

A great number of points on the thermometric titration curve are used. From the expression of the equilibrium constant and the charge, matter and heat balances, for each point the following results

$$-K_a \Delta H^{\ominus} = \frac{C_a C_b V_T}{Q_{T_i}} \Delta H^{\ominus} + (C_a + C_b) \Delta H^{\ominus} + \frac{Q_T}{V_T} \quad (1)$$

where, for the  $i$ th point considered.

$$Q_{T_i} = c \Delta T_i = (C_0 + V_i C_e \rho) \Delta T_i$$

$$C_a = \frac{C_a^0 V_i}{V_T} \quad \text{and} \quad C_b = \frac{C_b^0 V_0}{V_T}$$

where  $C_a^0$  is the concentration of titrant,  $C_b^0$  is the initial concentration of the amine in the thermometric cell,  $\Delta T_i$  is the temperature increment,  $V_i$  is

the volume of added titrant,  $V_0$  is the initial volume of the amine,  $V_T = V_0 + V_i$ ;  $Q_{Ti}$  is the heat liberated by adding  $V_i$ ,  $C_0$  is the initial heat capacity of the system,  $C_e$  is the specific heat capacity of the titrant, and  $\rho$  is the density of the solution to be titrated.

*Method A* Equation (1) may be reordered to give the final equation

$$\frac{V_0^2(C_a^0 - c_b^0) - V_0 V_T(K_a + C_a^0)}{C_0 V_T \Delta T} = \frac{1}{\Delta H^\ominus} + \frac{C_a^0 C_b^0 V_0^3 (V_T - V_0)}{C_0^2 V_T^2 \Delta T^2} \Delta H^\ominus \quad (2)$$

which allows the experimental data to be adjusted by means of the Gauss-Newton procedure to reach the value of  $\Delta H^\ominus$  from either the intercept or the slope. To apply this method of calculation, it is first necessary to know the value of the acidity constant.

*Method B* Rearranging eqn. (1), it is also found that

$$\frac{C_0 \Delta T V_T}{C_b^0 V_0^0} = -\Delta H^\ominus - \frac{C_0 \Delta T V_T K_a}{C_b^0 V_0^0 h} \quad (3)$$

which may be expressed in simplified form as

$$B = -\Delta H - (B/h)K_a \quad (4)$$

where  $B = C_0 \Delta T V_T / C_b^0 V_0^0$  and  $h$  is the proton concentration.

This expression is adjustable to the experimental values by means of the Gauss-Newton method. For its application, the value of the proton concentration  $h$  at each point must be known, either from a parallel potentiometric titration, or by calculating from a known  $pK_a$  value. As the  $pK_a$  values of the amine group were available [16], the second alternative was chosen. The Bronsted equation was then applied and the third-degree equation was solved by means of the iterative method of Newton and Raphson.

*Method C* This was used by Christensen et al. to simultaneously calculate the values of  $\Delta H$  and  $pK_a$ . Equation (1) may be represented in the form

$$-K_a \Delta H^\ominus = A \Delta H^\ominus + B \Delta H^\ominus + C \quad (5)$$

where

$$A = \frac{C_a C_b V_T}{Q_{Ti}}, \quad B = C_a + C_b \quad \text{and} \quad C = \frac{Q_{Ti}}{V_T}$$

As the first component remains constant throughout the titration, for any two points of the enthalpogram ( $i, j$ ), the following equation can be obtained

$$(A_i - A_j) \Delta H^\ominus + (B_i - B_j) \Delta H^\ominus + (C_i - C_j) = 0 \quad (6)$$

which allows evaluation of  $\Delta H^\ominus$  as  $A$ ,  $B$  and  $C$  are determined from the titration data.

TABLE 1

Neutralization enthalpy of Tris. Method A of the point-by-point heat capacity. 1; HCl 0.9834 M;  $C_s = 0.01250$  M. Initial heat capacity =  $0.0524 \text{ kcal } ^\circ\text{C}^{-1}$ ;  $V_0 = 50 \text{ ml}$ ;  $pK_a = 8.09$

$V_T$	$\Delta T$	$X$	$Y$	$D$
50.137	0.03200	2.978E-002	-0.451E+000	0.256E-003
50.177	0.04100	2.340E-002	-0.370E+000	1.622E-003
50.217	0.05100	1.851E-002	-0.312E+000	-0.922E-003
50.257	0.06000	1.582E-002	-0.277E+000	1.584E-004
50.297	0.07000	1.341E-002	-0.248E+000	-0.589E-003
50.337	0.08000	1.163E-002	-0.226E+000	-0.783E-003
50.378	0.09000	1.029E-002	-0.209E+000	-0.581E-003
50.418	0.10000	9.202E-003	-0.196E+000	-0.425E-003
50.458	0.11000	8.320E-003	-0.184E+000	-0.194E-003
50.498	0.12000	7.589E-003	-0.175E+000	7.122E-005
50.538	0.12900	7.084E-003	-0.168E+000	4.005E-004
50.578	0.13900	6.544E-003	-0.162E+000	6.316E-004
50.618	0.14900	6.080E-003	-0.156E+000	8.703E-004

$$\Delta H_{(\text{intercept})} = -12.1 \pm 0.00; \Delta H_{(\text{slope})} = -12.43 \pm 0.07; r = -1.0000; E = 7.6353E-004.$$

### Programs

A program package was initially developed for the enthalpy calculation of monoamines based on the use of the HP-85/HP-86 microcomputers. This package consists of four programs CAPUENC1-1, CAPUENC1-2, CAPUENC1-3 and POLI.

The first program CAPUENC1-1 corresponds to the point-by-point heat capacity method A. Data were introduced as lengths of  $Y$  and  $X$  coordinates measured directly from the graph paper. These data together with the values of the required parameters (initial concentrations of the sample and titrant,  $pK_a$ , initial volume of the sample  $V_0$ ,  $pK_w$ ,  $Y$  and  $X$  scale transformation coefficients to  $\Delta T$  and ml respectively, number of experimental points, etc) were only introduced once in this first program, as they were transferred by COMMON and CHAIN sentences to the other programs.

CAPUENC1-2 corresponds to method B and CAPUENC1-3 and POLI to method C.

Both methods A and B were solved by applying a linear regression fit, which could be iteratively used in order to select the most appropriate range of the experimental points. Before the linear fitting was applied, the Newton-Raphson method was used in method B to find the protonic concentration needed in eqn. (3). Tables 1 and 2 are examples of the results obtained with these two programs.

CAPUENC1-3 calculated the values of the parameters  $A$ ,  $B$  and  $C$  of each experimental point needed for method C. Table 3 shows the obtained values for a representative experiment. The program POLI ran all possible combinations of these points in pairs, each giving a value of the molar

TABLE 2

Neutralization enthalpy of Tris. Method B of the point-by-point heat capacity. Run 1; HCl 0.9834 M;  $C_s = 0.01250$  M. Initial heat capacity = 0.0524 kcal C<sup>-1</sup>;  $V_0 = 50$  ml;  $pK_a = 8.09$

$V_T$	$\Delta T$	pH	[H <sup>+</sup> ]	X	Y	D
50.137	0.03200	8.649	2.241E-009	1.200E+009	2.690E+000	2.427E-002
50.177	0.04100	8.502	3.144E-009	1.097E+009	3.450E+000	-0.111E+000
50.217	0.05100	8.375	4.220E-009	1.018E+009	4.294E+000	4.201E-002
50.257	0.06000	8.258	5.524E-009	9.153E+008	5.056E+000	-0.846E-001
50.297	0.07000	8.147	7.136E-009	8.273E+008	5.904E+000	-0.217E-002
50.337	0.08000	8.037	9.180E-009	7.355E+008	6.752E+000	4.916E-002
50.378	0.09000	7.923	1.194E-008	6.370E+008	7.603E+000	4.338E-002
50.418	0.10000	7.806	1.562E-008	5.411E+008	8.454E+000	6.179E-002
50.458	0.11000	7.678	2.097E-008	4.437E+008	9.307E+000	6.856E-002
50.498	0.12000	7.531	2.944E-008	3.452E+008	1.016E+001	6.648E-002
50.538	0.12900	7.348	4.484E-008	2.438E+008	1.093E+001	-0.436E-001
50.578	0.13900	7.088	8.165E-008	1.444E+008	1.179E+001	-0.506E-001
50.618	0.14900	6.544	2.860E-007	4.421E+007	1.265E+001	-0.629E-001

$\Delta H = -13.094 \pm 0.081$ ;  $K_a = 8.688E-009 \pm 1.119E-010$ ;  $r = -0.9998$ ;  $E = 6.5815E-002$ .

enthalpy. All outliers were excluded and an average value was calculated from the remainder.

In a second stage, the package was rewritten for an IBM-PC computer, all the methods being contained in a sole program, CAPUS1, which successively solves the three methods. The improved performance of this computer

TABLE 3

Neutralization enthalpy of Tris. Method C of the point-by-point heat capacity. Run 1; HCl 0.9834 M;  $C_s = 0.01250$  M. Initial heat capacity = 0.0524 kcal C<sup>-1</sup>;  $V_0 = 50$  ml;  $pK_a = 8.09$

$V_T$	$\Delta T$	A	B	C
50.016	0.00400	9.37772E-004	1.28106E-002	4.19194E-003
50.056	0.01200	1.09236E-003	1.35862E-002	1.25754E-002
50.096	0.02200	1.01983E-003	1.43606E-002	2.30540E-002
50.137	0.03200	9.98998E-004	1.51530E-002	3.35318E-002
50.177	0.04100	1.00577E-003	1.59249E-002	4.29611E-002
50.217	0.05100	9.89744E-004	1.66955E-002	5.34374E-002
50.257	0.06000	9.94808E-004	1.74649E-002	6.28653E-002
50.297	0.07000	9.83877E-004	1.82331E-002	7.33402E-002
50.337	0.08000	9.75321E-004	1.90001E-002	8.38143E-002
50.378	0.09000	9.70880E-004	1.97849E-002	9.42876E-002
50.418	0.10000	9.64759E-004	2.05494E-002	1.40760E-001
50.458	0.11000	9.59494E-004	2.13127E-002	1.15232E-001
50.498	0.12000	9.54871E-004	2.20748E-002	1.25703E-001
50.538	0.12900	9.58114E-004	2.28357E-002	1.35125E-001
50.578	0.13900	9.53819E-004	2.35953E-002	1.45596E-001
50.618	0.14900	9.49914E-004	2.45538E-002	1.56065E-001

dramatically decreases computing time, because compiled programs may be run. Other substantial advantages may be pointed out: (a) a greater number of points may be introduced, either manually or retrieved from data files; (b) experimental data files automatically generated by the VALTER program may be easily converted for direct use in CAPUS1; and (c) ASCII files of results are created, which allows their handling with standard word processors (like WORDPERFECT), thus facilitating report edition.

### *Calculation of the parameters for diamines*

#### *Overall heat capacity method*

The value of  $\Delta H_T = \Delta H_1 + \Delta H_2$  of the diamines can be determined by applying the overall heat capacity method described for the protonation of the amine group.

#### *Point-by-point heat capacity method*

As the value of  $pK_{a1}$  and  $pK_{a2}$  of the two amine groups are very close, it was necessary to simultaneously calculate the corresponding neutralization enthalpies. From the expressions for the equilibrium constants and the balances of matter, charge and heat, a final expression can be deduced

$$-\frac{C_0 V_T \Delta T}{K_1 C_b^0 V_0^2 h} (h^2 + K_1 h + K_1 K_2) = \Delta H_2^\ominus + \Delta H_T^\ominus \frac{h}{K_1} \quad (7)$$

which can be fitted into a linear equation, where  $\Delta H_2$  and  $\Delta H_T$  are the only unknown parameters, as the proton concentration  $h$  may be calculated by applying the Newton–Raphson iterative method to the equation

$$\begin{aligned} h^4 + \left( \frac{C_a^0 V_0}{V_T} - C_a^0 + \frac{2C_b^0 V_0}{V_T} + K_1 \right) h^3 \\ + \left( \frac{C_a^0 V_0 K_1}{V_T} - C_a^0 K_1 + \frac{C_b^0 V_0 K_1}{V_T} + K_1 K_2 - K_w \right) h^2 \\ + \left( \frac{C_a^0 V_0 K_1 K_2}{V_T} - C_a^0 K_1 K_2 - K_1 K_w \right) h - K_1 K_2 K_w = 0 \end{aligned} \quad (8)$$

#### *Programs*

As for the monoamines, a program, CAPU2-1, was first developed for the HP-85/HP-86 computers, and later rewritten for the IBM-PC and PC clones.

After data introduction, manually or from files previously created by VALTER, the required protonic concentration values in eqn. (7) were calculated by applying the Newton–Raphson method to eqn. (8).

A linear regression method was iteratively used in order to find the

TABLE 4

Neutralization enthalpy of 1,3-propanediamine. Method of the point-by-point heat capacity. Run 1; HCl 0.4840 M;  $C_s = 0.00435$  M; methanol-water (50% v/v). Initial heat capacity = 0.04165 kcal °C<sup>-1</sup>,  $V_0 = 50$  ml;  $pK_1 = 7.81$ ;  $pK_2 = 9.820$

$V_T$	$\Delta T$	pH	[H <sup>+</sup> ]	$X$	$Y$	$D$
50.173	0.02184	9.968	1.076E-010	6.948E-003	1.013E+001	-0.679E+000
50.240	0.02936	9.740	1.819E-010	1.175E-002	1.042E+001	-0.679E+000
50.269	0.03336	9.639	2.294E-010	1.481E-002	1.075E+001	-0.212E+000
50.336	0.04104	9.382	4.146E-010	2.677E-002	1.101E+001	-0.197E+000
50.365	0.04536	9.256	5.543E-010	3.579E-002	1.145E+001	6.043E-002
50.432	0.05280	8.908	1.235E-009	7.976E-002	1.226E+001	-0.198E-001
50.461	0.05736	8.743	1.808E-009	1.168E-001	1.331E+001	2.780E-001
50.528	0.06400	8.385	4.118E-009	2.659E-001	1.613E+001	8.712E-002
50.557	0.06800	8.254	5.570E-009	3.596E-001	1.826E+001	3.167E-001
50.624	0.07440	7.984	1.037E-008	6.697E-001	2.430E+001	8.046E-002
50.653	0.07864	7.876	1.329E-008	8.582E-001	2.852E+001	4.928E-001
50.720	0.08480	7.622	2.386E-008	1.540E+000	4.195E+001	1.215E-001
50.749	0.08824	7.504	3.131E-008	2.022E+000	5.191E+001	3.397E-001
50.816	0.09496	7.161	6.896E-008	4.453E+000	1.008E+002	6.658E-002
50.845	0.09784	6.944	1.138E-007	7.349E+000	1.591E+002	-0.244E+000

$\Delta H_1 = -9.563$ ;  $\Delta H_2 = -10.667 \pm 0.21$ ;  $\Delta H_T = -20.230 \pm 0.092$ ;  $r = +1.0000$ ;  $E = 3.3035E - 001$ .

interval range of data points which offered the best  $\Delta H_1^\ominus$  and  $\Delta H_2^\ominus$  values. Table 4 is representative of the results obtained.

### Refinement of the parameters

In MINITERM [17], the overall enthalpies and the logarithms of the overall stability constants are treated as unknown parameters, and the values which give the minimum non-weighted sum of the squares of the residuals ( $U$ ) of the measured ( $\Delta T_{\text{meas}}$ ) and calculated ( $\Delta T_{\text{calc}}$ ) temperature increments are calculated, together with the probable errors

$$\begin{aligned}
 U &= \sum_i (\Delta T_{\text{meas},i} - \Delta T_{\text{calc},i})^2 \\
 &= \sum_i \left( \Delta T_{\text{meas},i} + \left( \Delta H_M [M] + \Delta H_L [L] + \sum_j \Delta H_j B_j [M]^{qj} [L]^{pj} [H^+]^{rj} \right) \right. \\
 &\quad \left. \times V_0 / C_0 \times 1000 \right)^2 \quad (9)
 \end{aligned}$$

where  $\sum_i$  and  $\sum_j$  represent the summing of all ( $q$ ,  $p$ ,  $r$ ) complex species and experimental points, respectively,  $\Delta H_M$  and  $\Delta H_L$  are the "apparent" dilution enthalpies of the metal and ligand, respectively,  $\Delta H_j$  the enthalpies of the complex species (all enthalpies in cal mol<sup>-1</sup>),  $V_0$  the initial volume (ml<sup>-1</sup>) and  $C_0$  the initial heat capacity (in cal °C<sup>-1</sup>).



For MINITERM the following equilibria can be considered

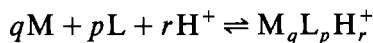

$$\beta = [M_qL_pH_r^+] / ([M]^q [L]^p [H^+]^r)$$

$$\Delta H_j = -n_j Q_j = -n_j (C_0 V_{\text{Tot}} / V_0) \Delta T$$

Because zero values for  $q$  are allowed, equilibria involving protonation of amines ( $+r$ ,  $+\log \beta^H$ ) or deprotonation of carboxylic acids ( $-r$ ,  $-\log \beta^H$ ) may be considered, i.e. only  $H_rL_p$  complexes are formed.

MINITERM can treat a maximum of 80 experimental points measured at the titration curve and a maximum number of eight species formed. Consequently, the maximum number of parameters is 18, because the last two parameters are always the "dilution enthalpies" of the reacting species M and L, in that order.

MINITERM allows the simultaneous refinement of a maximum of only four arbitrarily chosen parameters. When  $\log \beta$  and  $\Delta H$  values are refined

TABLE 5

Refinement of the enthalpy and pK values of 1,3-propanediamine (methanol-water 50%)

ml	pH	Tot. M	Tot. L	$\Delta T_m$	$\Delta T_c$	$D$
0.173	9.968	0.100E+01	0.434E-02	0.02184	0.02224	-0.00040
0.240	9.740	0.100E+01	0.434E-02	0.02936	0.02974	-0.00038
0.269	9.639	0.100E+01	0.434E-02	0.03336	0.03311	0.00025
0.336	9.382	0.100E+01	0.434E-02	0.04104	0.04123	-0.00019
0.365	9.256	0.100E+01	0.434E-02	0.04536	0.04479	0.00057
0.432	8.908	0.100E+01	0.434E-02	0.05280	0.05313	-0.00033
0.461	8.743	0.100E+01	0.434E-02	0.05736	0.05662	0.00074
0.528	8.385	0.100E+01	0.434E-02	0.06400	0.06449	-0.00049
0.557	8.254	0.100E+01	0.434E-02	0.06800	0.06773	0.00027
0.624	7.984	0.100E+01	0.434E-02	0.07440	0.07509	-0.00069
0.653	7.876	0.100E+01	0.434E-02	0.07864	0.07817	0.00047
0.720	7.622	0.100E+01	0.434E-02	0.08480	0.08520	-0.00040
0.749	7.504	0.100E+01	0.434E-02	0.08824	0.08815	0.00009
0.816	7.161	0.100E+01	0.434E-02	0.09496	0.09492	0.00004
0.845	6.944	0.100E+01	0.434E-02	0.09784	0.09766	0.00018
Q <sup>a</sup>	P <sup>a</sup>	R <sup>a</sup>	Log $\beta$	$\Delta H$ (cal mol <sup>-1</sup> )		
0	1	1	9.776	-10810		
0	1	2	17.618	-20078		

$$\Delta H_{\text{metal}} = 0.000E+00$$

$$\Delta H_{\text{ligand}} = 0.000E+00$$

$$\text{Root of residuals} = 0.2582E-05$$

$$\text{Standard deviation} = 0.5081E-03$$

<sup>a</sup>Q, P and R are the stoichiometric coefficients of the metal, ligand and proton, respectively.

simultaneously, the serial numbers of  $\Delta H$  values must always precede those of the  $\log \beta$  values.

Table 5 shows the results obtained in the refinement of the enthalpies from an experimental titration of a diamine. The values of  $U$  (residuals) and  $s$  (standard deviation) can be seen, calculated with linear least-squares methods (point-by-point heat capacity methods) and the same values after refinement with MINITERM.

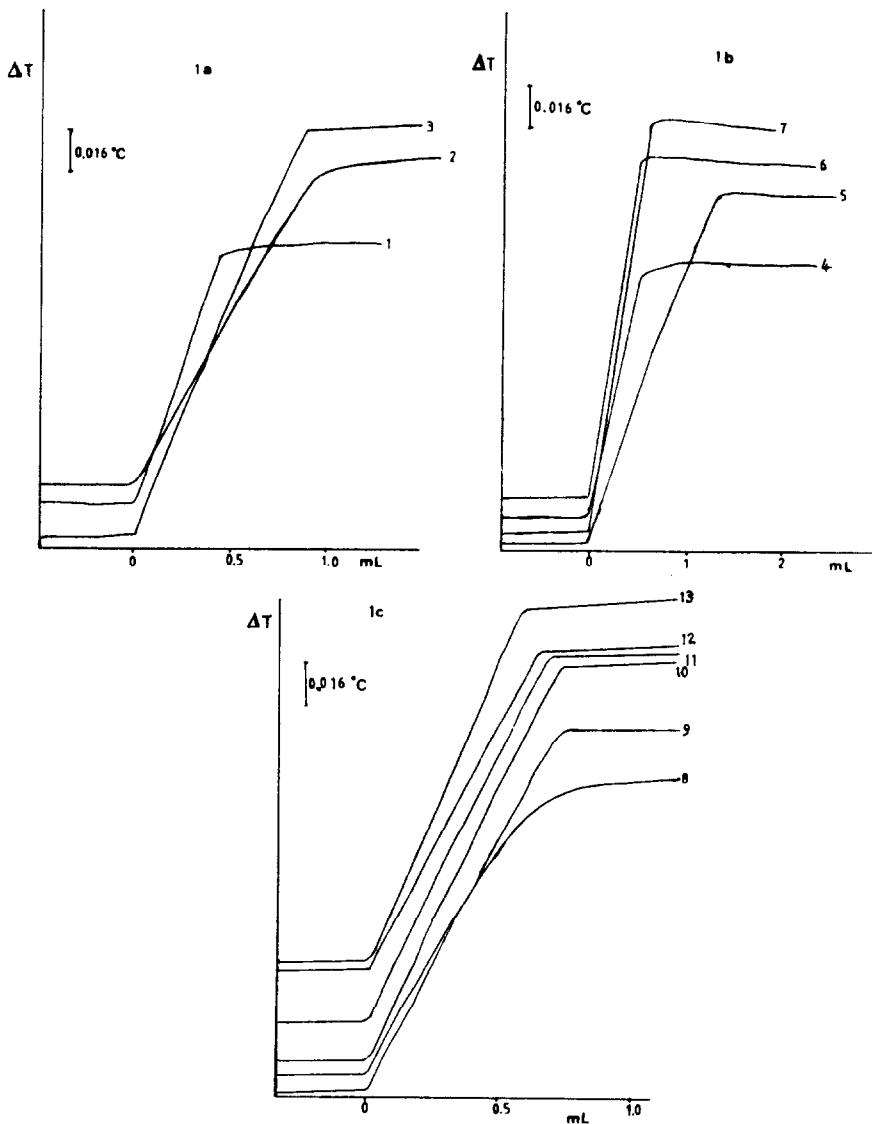

Fig. 1. Thermometric curves in aqueous medium for: (1) *N*-benzylmethylamine; (2) 1,2-phenylenediamine; (3) ethylenediamine; (4) 2-aminopyridine; (5) pyridine; (6) ethylamine; (7) methylamine; (8) triethylenetetramine; (9) ethanolamine; (10) 1,3-propanediamine; (11) ammonia; and (12) Tris.

## RESULTS AND DISCUSSION

*Titration curves and titration errors*

The titration curves in water and in methanol–water medium of a number of amines are shown in Figs. 1 and 2.

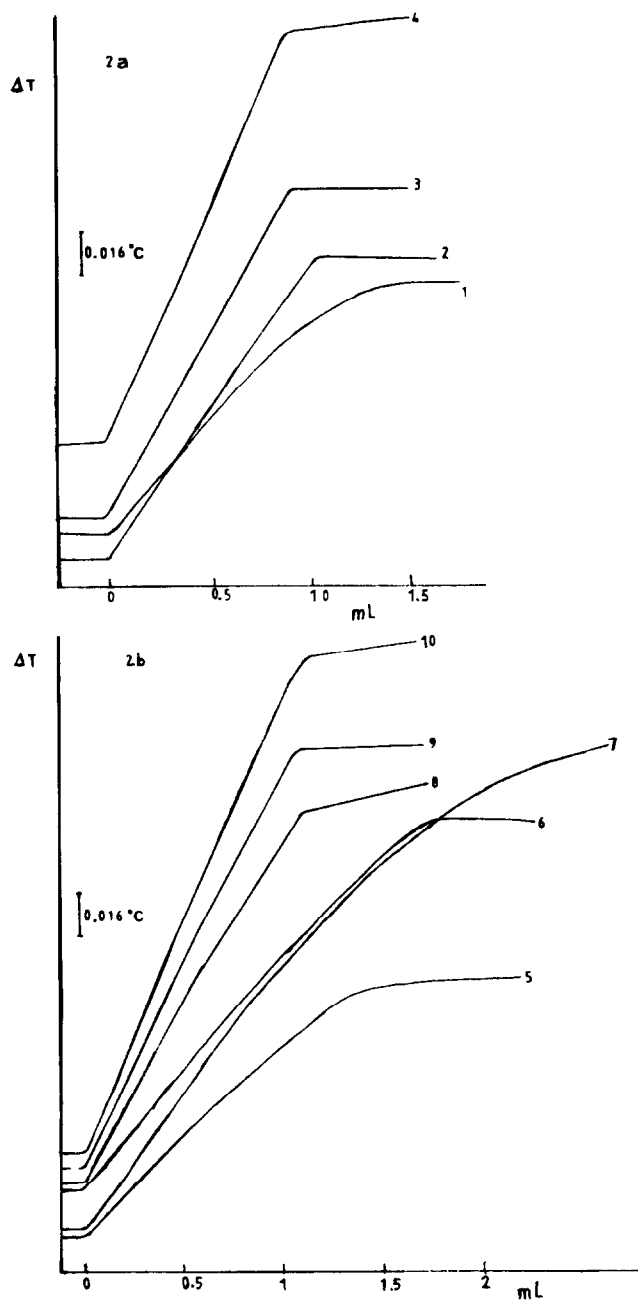

Fig. 2 (continued).

The titration curves resulting from water show, for most of the amines, well-defined end points. However, analytical results are not always good

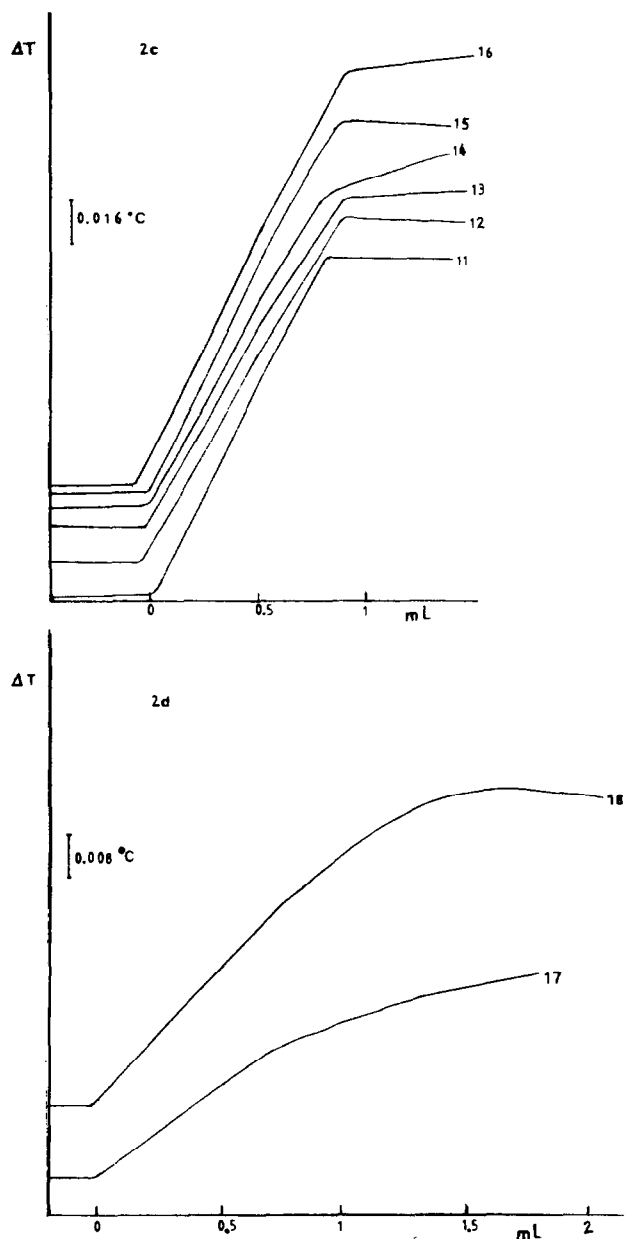

Fig. 2. Thermometric curves in methanol-water (50% v/v) medium for: (1) *o*-dianisidine; (2) 2,6-diaminopyridine; (3) Tris; (4) ethylamine; (5) pyridine; (6) 1,2-phenylenediamine; (7) benzidine; (8) 2-aminopyridine; (9) ethanolamine; (10) methylamine; (11) *n*-butylamine; (12) *N*-benzylmethylamine; (13) ethylenediamine; (14) triethylenetetramine; (15) 1,3-propanediamine; (16) ammonia; (17) 2-amino-3-nitropyridine; and (18) 3,5-diaminobenzoic acid.

(Table 6), mainly due to some of them having a lower solubility in water (3,5-diaminobenzoic acid can be taken as an example). These problems can be overcome in the hydro-methanolic medium, where titration errors and precision sometimes improve.

Tris gives very good results in both media, and therefore can be used as a standard for thermometric titrations in water and in methanol–water, while 2,6-diaminopyridine can be used as a standard only in methanol–water.

TABLE 6

Titration errors and precision in water and methanol–water (50% v/v)

Amine	Medium	Sample (mmol)	Found (mmol)	Error (%)	$\sigma$ ( $\times 100$ )	r.s.d. (%)
Ammonia	Water	0.6422	0.6608	2.91	0.46	0.69
	Methanol/water	0.4598	0.4810	4.63	0.38	0.38
Methylamine	Water	0.6245	0.6028	-3.46	0.53	0.87
	Methanol/water	0.5793	0.5682	-1.92	0.55	0.47
Ethylamine	Water	0.5212	0.5015	-3.80	1.72	3.37
	Methanol/water	0.4743	0.4637	-2.24	1.48	1.54
Ethanolamine	Water	0.7061	0.6962	-1.67	1.46	2.07
	Methanol/water	0.5643	0.5392	-4.46	0.45	0.41
Ethylenediamine	Water	0.3501	0.3432	-1.97	0.58	0.84
	Methanol/water	0.2178	0.2222	2.00	0.55	0.60
1,3-Propane-diamine	Water	0.3565	0.3540	-0.69	0.34	0.48
	Methanol/water	0.2217	0.2176	-1.86	1.10	1.22
<i>n</i> -Butylamine	Water	0.5802	0.5645	-2.71	2.00	3.48
	Methanol/water	0.4124	0.3964	-3.87	0.35	0.43
Triethylenetetramine	Water	0.1977	0.2019	2.16	2.10	3.41
	Methanol/water	0.1397	0.1339	-4.15	0.45	0.55
Trishydroxymethyl-aminomethane	Water	0.6176	0.6245	1.11	0.10	0.16
	Methanol/water	0.4669	0.4622	1.20	0.07	0.08
1,2-Phenylene-diamine	Water	0.8890	0.8733	-1.81	1.45	1.64
	Methanol/water	0.4138	0.4225	2.06	8.91	5.62
3,5-Diaminobenzoic acid	Water	-	-	-	-	-
	Methanol/water	0.2594	0.2551	-1.68	1.27	1.08
2,6-Diaminopyridine	Water	-	-	-	-	-
	Methanol/water	0.1408	0.1418	0.69	0.25	0.24
Benzidine	Water	-	-	-	-	-
	Methanol/water	0.4985	0.4688	-5.96	0.97	0.50
<i>o</i> -Dianisidine	Water	-	-	-	-	-
	Methanol/water	0.2471	0.2299	6.96	0.21	0.24
<i>N</i> -Benzylmethylamine	Water	0.4111	0.4297	4.55	0.23	0.54
	Methanol/water	0.4506	0.4612	2.31	0.68	0.73
Pyridine	Water	1.2902	1.3020	0.91	0.76	0.57
	Methanol/water	0.6728	0.6132	-8.85	2.56	2.02
2-Aminopyridine	Water	0.4848	0.5281	8.92	1.93	3.59
	Methanol/water	0.5406	0.5397	-0.18	0.20	0.18
2-Amino-3-nitropyridine	Water	-	-	-	-	-
	Methanol/water	0.1859	0.1936	4.17	0.21	0.24

TABLE 7  
Thermodynamic parameters of the amines in aqueous medium <sup>a</sup>

Amine	Method C	Method B	Method A	Method ohc <sup>b</sup>	MINITERM	pK <sub>a</sub>
Ammonia	$\Delta H = -13.49$	$\Delta H = -14.04 \pm 0.16$	$\Delta H = -13.20 \pm 0.00$	$\Delta H = -13.48$	$\Delta H = -13.98$	9.27
	$r = 0.9992$	$r = 0.9992$	$\Delta H = -13.32 \pm 0.01$		pK <sub>a</sub> = 9.24	
	$U = 0.7656 \text{ E-}4$	$U = 0.7656 \text{ E-}4$	$r = 1.0000$		$U = 0.9317 \text{ E-}5$	
Methylamine	$\Delta H = -13.42$	$\Delta H = -13.56 \pm 0.38$	$\Delta H = -12.81 \pm 0.00$	$\Delta H = -13.20$	$\sigma = 0.1017 \text{ E-}2$	10.64
		$r = 0.9966$	$\Delta H = -13.02 \pm 0.16$		$\Delta H = -13.53$	
		$U = 0.1469 \text{ E-}3$	$r = 0.9999$		pK <sub>a</sub> = 10.58	
Ethylamine	$\Delta H = -13.50$	$\Delta H = -13.98 \pm 0.81$	$\Delta H = -13.25 \pm 0.00$	$\Delta H = -13.65$	$U = 0.9519 \text{ E-}5$	10.64
		$r = 0.9949$	$\Delta H = -13.48 \pm 0.17$		$\sigma = 0.1543 \text{ E-}2$	
		$U = 0.1081 \text{ E-}3$	$r = 0.9999$		$\Delta H = -13.94$	
Ethanolamine	$\Delta H = -13.29$	$\Delta H = -13.58 \pm 0.11$	$\Delta H = -13.11 \pm 0.00$	$\Delta H = -12.99$	pK <sub>a</sub> = 10.56	9.52
		$r = 0.9997$	$\Delta H = -13.18 \pm 0.07$		$U = 0.3578 \text{ E-}5$	
		$U = 0.4038 \text{ E-}4$	$r = 1.0000$		$\sigma = 0.1338 \text{ E-}2$	
<i>n</i> -Butylamine	$\Delta H = -14.97$	$\Delta H = -15.71 \pm 0.00$	$\Delta H = -14.70 \pm 0.00$	$\Delta H = -13.93$	$\Delta H = -13.58$	10.64
		$r = 0.9995$	$\Delta H = -14.88 \pm 0.08$		pK <sub>a</sub> = 9.50	
		$U = 0.1041 \text{ E-}3$	$r = 1.0000$		$U = 0.3512 \text{ E-}5$	
		$\sigma = 0.5891 \text{ E-}2$			$\sigma = 0.6625 \text{ E-}3$	
					$\Delta H = -15.69$	
					pK <sub>a</sub> = 10.57	
					$U = 0.9377 \text{ E-}6$	
					$\sigma = 0.6847 \text{ E-}3$	

Trishydroxy- methyl- aminomethane	$\Delta H = -12.47$	$\Delta H = -13.09 \pm 0.08$ $r = 0.9998$ $U = 0.5186 \text{ E-}4$ $\sigma = 0.2171 \text{ E-}2$	$\Delta H = -12.31 \pm 0.00$ $\Delta H = -12.43 \pm 0.07$ $r = 1.0000$	$\Delta H = -12.47$	$\Delta H = -13.07$ $pK_a = 8.06$ $U = 0.2130 \text{ E-}5$ $\sigma = 0.4615 \text{ E-}3$	8.09					
							$\Delta H = -7.29$	$\Delta H = -7.04 \pm 0.00$ $\Delta H = -7.13 \pm 0.04$ $r = 1.000$	$\Delta H = -7.20$	$\Delta H = -7.00$ $pK_a = 4.69$ $U = 0.8697 \text{ E-}4$ $\sigma = 0.2949 \text{ E-}2$	4.63
N-Benzylmethyl- amine	$\Delta H = -5.80$	$\Delta H = -5.71 \pm 0.02$ $\Delta H = -5.94 \pm 0.12$ $r = 0.9996$ $U = 0.2696 \text{ E-}3$ $\sigma = 0.6206 \text{ E-}2$	$\Delta H = -5.40$	$\Delta H = -5.52$ $pK_a = 5.32$ $U = 0.1810 \text{ E-}5$ $\sigma = 0.5492 \text{ E-}3$	5.23						
						Pyridine	$\Delta H = -9.31$	$\Delta H = -9.20 \pm 0.01$ $\Delta H = -9.27 \pm 0.19$ $r = 0.9996$ $U = 0.1510 \text{ E-}4$ $\sigma = 0.1469 \text{ E-}2$	$\Delta H = -9.63$	$\Delta H = -9.70$ $pK_a = 6.67$ $U = 0.3628 \text{ E-}5$ $\sigma = 0.7776 \text{ E-}3$	6.70

<sup>a</sup>  $\Delta H$  in kcal mol<sup>-1</sup>

<sup>b</sup> ohc, overall heat capacity.

TABLE 8  
Thermodynamic parameters of the amines in methanol-water (50% v/v) <sup>a</sup>

Amine	Method C	Method B	Method A	Method ohc <sup>b</sup>	MINITERM	pK <sub>a</sub>
Ammonia	$\Delta H = -11.61$	$\Delta H = -10.86 \pm 0.10$	$\Delta H = -12.20 \pm 0.00$	$\Delta H = -12.81$	$\Delta H = -10.86$	
		$r = 0.9994$	$\Delta H = -11.85 \pm 0.15$		$pK_a = 8.83$	8.79
		$U = 0.1107 E-3$ $\sigma = 0.2630 E-2$	$r = 0.9998$		$U = 0.3969 E-5$ $\sigma = 0.5144 E-3$	
Methylamine	$\Delta H = -11.36$	$\Delta H = -11.62 \pm 0.08$	$\Delta H = -11.13 \pm 0.00$	$\Delta H = -12.90$	$\Delta H = -11.65$	
		$r = 0.9998$	$\Delta H = -11.22 \pm 0.07$		$pK_a = 10.11$	10.16
		$U = 0.1417 E-3$ $\sigma = 0.4500 E-2$	$r = 0.9999$		$U = 0.4904 E-6$ $\sigma = 0.2859 E-3$	
Ethylamine	$\Delta H = -12.06$	$\Delta H = -12.07 \pm 0.24$	$\Delta H = -12.05 \pm 0.00$	$\Delta H = -13.48$	$\Delta H = -12.04$	
		$r = 0.9980$	$\Delta H = -12.06 \pm 0.08$		$pK_a = 10.12$	10.16
		$U = 0.6510 E-4$ $\sigma = 0.2853 E-2$	$r = 0.9999$		$U = 0.7258 E-5$ $\sigma = 0.1018 E-2$	
Ethanolamine	$\Delta H = -9.98$	$\Delta H = -9.64 \pm 0.07$	$\Delta H = -10.31 \pm 0.00$	$\Delta H = -11.82$	$\Delta H = -9.66$	
		$r = 0.9996$	$\Delta H = -10.13 \pm 0.07$		$pK_a = 9.05$	9.04
		$U = 0.1912 E-4$ $\sigma = 0.1169 E-2$	$r = 0.9999$		$U = 0.3241 E-5$ $\sigma = 0.4993 E-3$	
<i>n</i> -Butylamine	$\Delta H = -11.62$	$\Delta H = -10.82 \pm 0.19$	$\Delta H = -12.81 \pm 0.00$	$\Delta H = -13.24$	$\Delta H = -10.81$	
		$r = 0.9983$	$\Delta H = -12.07 \pm 0.11$		$pK_a = 10.16$	10.16
		$U = 0.1743 E-5$ $\sigma = 0.5389 E-3$	$r = 0.9999$		$U = 0.1744 E-5$ $\sigma = 0.5906 E-3$	
Trishydroxy-methyl-aminomethane	$\Delta H = -10.92$	$\Delta H = -10.22 \pm 0.160$	$\Delta H = -11.26 \pm 0.00$	$\Delta H = -12.48$	$\Delta H = -10.32$	
		$r = 0.9986$	$\Delta H = -11.02 \pm 0.08$		$pK_a = 7.64$	7.61
		$U = 0.8989 E-4$ $\sigma = 0.2370 E-2$	$r = 0.9999$		$U = 0.1836 E-5$ $\sigma = 0.3499 E-3$	
2-Amino-3-nitro-	$\Delta H = -2.50$	$\Delta H = -2.42 \pm 0.040$	$\Delta H = -2.21 \pm 0.02$	$\Delta H = -2.31$	$\Delta H = -2.41$	



pyridine	$r = 0.9976$ $U = 0.2819 \text{ E-}5$ $\sigma = 0.4847 \text{ E-}3$	$\Delta H = -2.31 \pm 0.04$ $r = 0.9996$	$pK_a = 6.38$ $U = 0.6936 \text{ E-}6$ $\sigma = 0.2511 \text{ E-}3$	6.34
2-Aminopyridine	$\Delta H = -8.31$ $r = 0.9996$ $U = 0.1364 \text{ E-}4$ $\sigma = 0.8956 \text{ E-}3$	$\Delta H = -8.30 \pm 0.00$ $\Delta H = -8.31 \pm 0.02$ $r = 1.0000$	$\Delta H = -8.09$ $pK_a = 6.24$ $U = 0.2534 \text{ E-}5$ $\sigma = 0.3979 \text{ E-}3$	6.22
3,5-Diaminobenzoic acid	$\Delta H = -3.76$ $r = 0.9991$ $U = 0.1491 \text{ E-}4$ $\sigma = 0.8634 \text{ E-}3$	$\Delta H = -3.65 \pm 0.01$ $\Delta H = -3.70 \pm 0.03$ $r = 0.9998$	$\Delta H = -3.60$ $pK_a = 4.36$ $U = 0.1058 \text{ E-}5$ $\sigma = 0.2359 \text{ E-}3$	4.27
1,2-Phenylene-diamine	$\Delta H = -6.62$ $r = 0.9992$ $U = 0.1621 \text{ E-}3$ $\sigma = 0.3287 \text{ E-}2$	$\Delta H = -6.30 \pm 0.01$ $\Delta H = -6.68 \pm 0.05$ $r = 0.9999$	$\Delta H = -6.50$ $pK_a = 4.20$ $U = 0.2032 \text{ E-}5$ $\sigma = 0.3810 \text{ E-}3$	4.15
2,6-Diaminopyridine	$\Delta H = -9.05$ $r = 0.9998$ $U = 0.1400 \text{ E-}4$ $\sigma = 0.9661 \text{ E-}3$	$\Delta H = -9.27 \pm 0.00$ $\Delta H = -9.13 \pm 0.04$ $r = 1.0000$	$\Delta H = -8.78$ $pK_a = 6.02$ $U = 0.1246 \text{ E-}5$ $\sigma = 0.2984 \text{ E-}3$	6.00
<i>N</i> -Benzylmethylamine	$\Delta H = -9.77$ $r = 0.9991$ $U = 0.1030 \text{ E-}3$ $\sigma = 0.2930 \text{ E-}2$	$\Delta H = -10.37 \pm 0.00$ $\Delta H = -10.00 \pm 0.18$ $r = 0.9997$	$\Delta H = -8.98$ $pK_a = 9.12$ $U = 0.2989 \text{ E-}5$ $\sigma = 0.5212 \text{ E-}3$	9.06
Pyridine	$\Delta H = -5.47$ $r = 0.9997$ $U = 0.3152 \text{ E-}4$ $\sigma = 0.1450 \text{ E-}2$	$\Delta H = -4.70 \pm 0.01$ $\Delta H = -5.05 \pm 0.05$ $r = 0.9998$	$\Delta H = -5.16$ $pK_a = 4.79$ $U = 0.1184 \text{ E-}5$ $\sigma = 0.2439 \text{ E-}4$	4.75

<sup>a</sup>  $\Delta H$  in kcal mol<sup>-1</sup>.<sup>b</sup> ohc, overall heat capacity.

Table 6 shows titration errors and precision in water and methanol–water, which correspond to those usually obtained in thermometric titrations. The hydro-alcoholic medium sometimes improves the results with respect to water (2-aminopyridine and *N*-benzylmethylamine), although this is not always true (pyridine). A number of amines give rounded titration curves (3,5-diaminobenzoic acid, pyridine, 2-amino-3-nitropyridine and *o*-dianisidine), which lead to higher titration errors, except for 3,5-diaminobenzoic acid.

In the methanol–water medium, ethylenediamine and 1,3-propanediamine, among the diamines, show well-defined titration curves whose end points correspond to the simultaneous neutralization of both groups. The behaviour of benzidine is similar, but it presents a very rounded end point. *o*-Dianisidine also gives one end point, which corresponds to the titration of one of its amine groups.

Comparing the different methods for enthalpy calculation of monoamines (Tables 7 + 8), and taking as a reference the refined values obtained by MINITERM, one can observe that in both aqueous and hydro-alcoholic media the overall heat capacity and methods A and C give lower results, whereas method B generally agrees with the refined values, with the additional advantage of giving the pH values needed in the refinement program.

For diamines (Tables 9 + 10), the overall heat capacity method also gives lower results than MINITERM. On the other hand, although the  $\Delta H_T$  values obtained by the point-by-point method agree with the refined values

TABLE 9

Thermodynamic parameters of the diamines in aqueous medium <sup>a</sup>

Diamine	Method pbp <sup>b</sup>	Method ohc <sup>c</sup>	MINITERM	pK <sub>a</sub>
1,3-Propanediamine	$\Delta H_2 = -14.12 \pm 0.65$		$\Delta H_2 = -14.92$	
	$\Delta H_1 = -13.87$		$\Delta H_1 = -13.08$	
	$\Delta H_T = -28.00 \pm 0.17$	$\Delta H_T = -27.08$	$pK_{a2} = 10.17$	$pK_{a2} = 10.30$
	$r = 1.0000$		$pK_{a1} = 8.29$	$pK_{a1} = 8.29$
	$U = 0.1147 \text{ E} - 3$		$U = 0.1782 \text{ E} - 4$	
Ethylenediamine	$\sigma = 0.2970 \text{ E} - 2$		$\sigma = 0.1335 \text{ E} - 2$	
	$\Delta H_2 = -11.46 \pm 1.96$		$\Delta H_2 = -13.63$	
	$\Delta H_1 = -11.78$		$\Delta H_1 = -10.90$	
	$\Delta H_T = -23.23 \pm 0.56$	$\Delta H_T = -22.16$	$pK_{a2} = 9.74$	$pK_{a2} = 9.89$
	$r = 0.9993$		$pK_{a1} = 6.67$	$pK_{a1} = 7.08$
	$U = 0.6148 \text{ E} - 3$		$U = 0.4296 \text{ E} - 3$	
	$\sigma = 0.7158 \text{ E} - 2$		$\sigma = 0.6250 \text{ E} - 2$	

<sup>a</sup>  $\Delta H$  in kcal mol<sup>-1</sup>.<sup>b</sup> pbp, point-by-point heat capacity.<sup>c</sup> ohc, overall heat capacity.

TABLE 10

Thermodynamic parameters of the diamines in methanol-water (50% v/v)<sup>a</sup>

Diamine	Method pbb <sup>b</sup>	Method ohc <sup>c</sup>	MINITERM	pK <sub>a</sub>
<i>o</i> -Dianisidine	$\Delta H_2 = -7.43 \pm 0.06$		$\Delta H_2 = -7.35$	
	$\Delta H_1 = -1.41$		$\Delta H_1 = -2.14$	
	$\Delta H_T = -8.85 \pm 0.62$	$\Delta H_T = -8.10$	$pK_{a2} = 3.97$	$pK_{a2} = 3.97$
	$r = 0.9901$		$pK_{a1} = 2.74$	$pK_{a1} = 2.74$
	$U = 0.3830 \text{ E}-5$		$U = 0.2555 \text{ E}-5$	
	$\sigma = 0.4613 \text{ E}-3$		$\sigma = 0.3874 \text{ E}-3$	
Benzidine	$\Delta H_2 = -7.82 \pm 0.06$		$\Delta H_2 = -7.79$	
	$\Delta H_1 = -7.77$		$\Delta H_1 = -8.09$	
	$\Delta H_T = -15.59 \pm 0.10$	$\Delta H_T = -13.51$	$pK_{a2} = 4.18$	$pK_{a2} = 4.17$
	$r = 0.9999$		$pK_{a1} = 2.92$	$pK_{a1} = 2.95$
	$U = 0.1833 \text{ E}-5$		$U = 0.1015 \text{ E}-5$	
	$\sigma = 0.3908 \text{ E}-3$		$\sigma = 0.3357 \text{ E}-3$	
1,3-Propanediamine	$\Delta H_2 = -10.67 \pm 0.21$		$\Delta H_2 = -10.81$	
	$\Delta H_1 = -9.56$		$\Delta H_1 = -9.27$	
	$\Delta H_T = -20.23 \pm 0.09$	$\Delta H_T = -21.65$	$pK_{a2} = 9.78$	$pK_{a2} = 9.82$
	$r = 1.0000$		$pK_{a1} = 7.84$	$pK_{a1} = 7.81$
	$U = 0.1037 \text{ E}-4$		$U = 0.2582 \text{ E}-5$	
	$\sigma = 0.8933 \text{ E}-3$		$\sigma = 0.5081 \text{ E}-3$	
Ethylenediamine	$\Delta H_2 = -9.25 \pm 0.14$		$\Delta H_2 = -9.28$	
	$\Delta H_1 = -7.51$		$\Delta H_1 = -7.69$	
	$\Delta H_T = -16.75 \pm 0.08$	$\Delta H_T = -20.31$	$pK_{a2} = 9.42$	$pK_{a2} = 9.41$
	$r = 1.0000$		$pK_{a1} = 6.54$	$pK_{a1} = 6.60$
	$U = 0.6007 \text{ E}-5$		$U = 0.2314 \text{ E}-5$	
	$\sigma = 0.6550 \text{ E}-3$		$\sigma = 0.4586 \text{ E}-3$	

<sup>a</sup>  $\Delta H$  in kcal mol<sup>-1</sup>.<sup>b</sup> pbb, point-by-point heat capacity.<sup>c</sup> ohc, overall heat capacity.

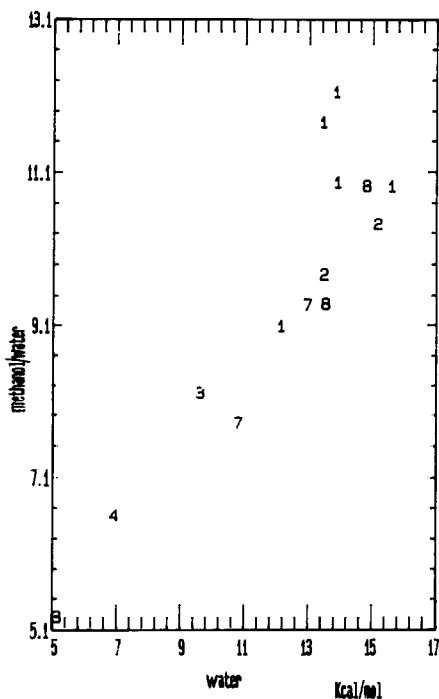

Fig. 3. Plot of enthalpies of amines obtained in methanol–water (50% v/v) vs. water: (1) aliphatic; (2) aliphatic polyfunctionals; (3) pyridines; (4) aromatic amines; (5) benzidines, first amine group; (6) benzidines, second amine group; (7) aliphatic diamines, first amine group; and (8) aliphatic diamines, second amine group.

of MINITERM, this program distributes the individual enthalpies in a different way than does the former one.

Figure 3 shows a good relationship between the enthalpies resulting in water and methanol–water, except for aliphatic amines. Figures 4 and 5 also demonstrate the relationship between  $pK$  and enthalpy values, although there is a greater dispersion, especially in methanol–water.

The enthalpies from the aqueous medium are generally 3–4 kcal mol<sup>-1</sup> higher than those obtained in the hydro-alcoholic one. Taking into account the different families of amines considered in the present paper, one can establish a qualitative relationship between the values of the enthalpies and the kind of nitrogen participating in the neutralization process (aliphatic > aromatic > pyridines).

#### ACKNOWLEDGMENTS

Thanks are due to the DGICyT (Spanish Council for Research in Science and Technology) for financial support (PA 86-0033).

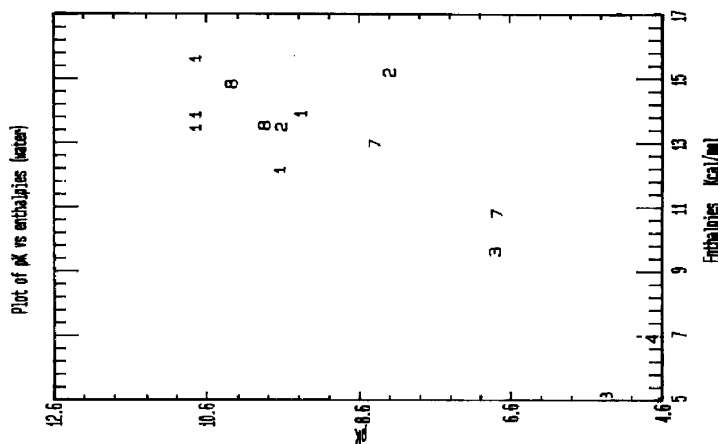

Fig. 4. Plot of  $pK_a$  values of a number of amines versus enthalpies in a methanol-water medium (50% v/v): (1) aliphatic; (2) aliphatic polyfunctionals; (3) pyridines; (4) aromatic amines; (5) benzidines, first amine group; (6) benzidines, second amine group; (7) aliphatic diamines, first amine group; and (8) aliphatic diamines, second amine group.

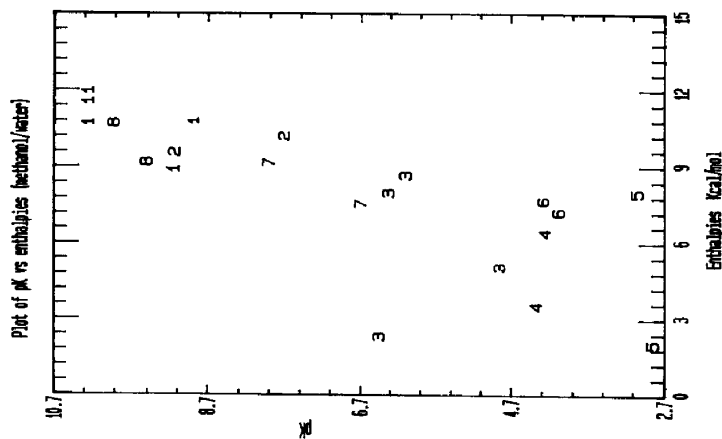

Fig. 5. Plot of  $pK_a$  values of a number of amines versus enthalpies in a water medium: (1) aliphatic; (2) aliphatic polyfunctionals; (3) pyridines; (4) aromatic amines; (5) benzidines, first amine group; (6) benzidines, second amine group; (7) aliphatic diamines, first amine group; and (8) aliphatic diamines, second amine group.

## REFERENCES

- 1 J.J. Christensen, H.D. Jonnston and R.M. Izatt, *J. Chem. Soc.*, (1970) 454.
- 2 J.J. Christensen, R.M. Izatt and L.D. Hansen, *J. Am. Chem. Soc.*, 89 (1967) 213.
- 3 J.L. Burgot, *Talanta*, 25 (1978) 233.
- 4 J.J. Christensen, J.L. Oscarson and R.M. Izatt, *J. Am. Chem. Soc.*, 90 (1968) 5949.
- 5 J.J. Christensen, M.D. Slade, D.E. Smith, R.M. Izatt and J. Tsang, *J. Am. Chem. Soc.*, 92 (1970) 4164.
- 6 L. Avedikian, *Bull. Soc. Chim. Fr.*, 8 (1966) 2570.
- 7 J.J. Christensen, D.P. Vradhall, R.M. Izatt and D.O. Tolman, *J. Phys. Chem.*, 71 (1967) 3001.
- 8 R.J.N. Harris, *Talanta*, 15 (1968) 1345.
- 9 G.A. Vaughan and J.J. Swithenbank, *Analyst*, 90 (1965) 594.
- 10 C.J. Quilty, *Anal. Chem.*, 39 (1967) 666.
- 11 Z. Paulak and A.A. Hampton, *Thermochim. Acta*, 59 (1982) 313.
- 12 E.J. Forman and D.N. Hume, *J. Phys. Chem.*, 63 (1959) 1949.
- 13 T.E. Mead, *J. Phys. Chem.*, 66 (1962) 2149.
- 14 V. Cerdá, E. Casassas and F. García-Montelongo, *Thermochim. Acta*, 47 (1981) 343.
- 15 V. Cerdá, M.T. Oms, A. Alvarez-Ossorio, X. Lumbarres and R. Forteza, *Thermochim. Acta*, 128 (1988) 9-19.
- 16 R.M. Smith and A.E. Martell, *Critical Stability Constants*, Vol. 2, Plenum, New York, 1975.
- 17 V. Cerdá, J.M. Estela and R. Jara, *Thermochim. Acta*, 87 (1985) 13.